

DSP&P Baldwin 2-8-0

This was for commercial development of the DSP&P Baldwin 2-8-0 #51 from 1880.

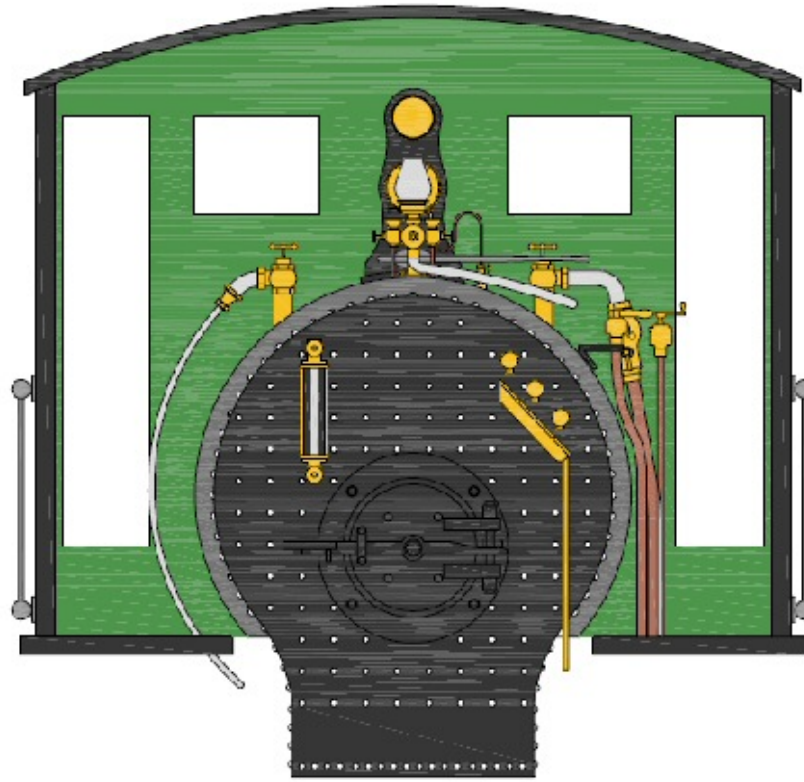

DSP&P #191 - CAB COLOUR SCHEME



BACKHEAD AND CAB INTERIOR COLOUR SCHEME
REBUILT CONFIGURATION 1885 BY U.P.R.R.

DSP&P #191 - 1885
DRAWN BY DAVID FLETCHER 2007

([click here for full size PDF file](#))

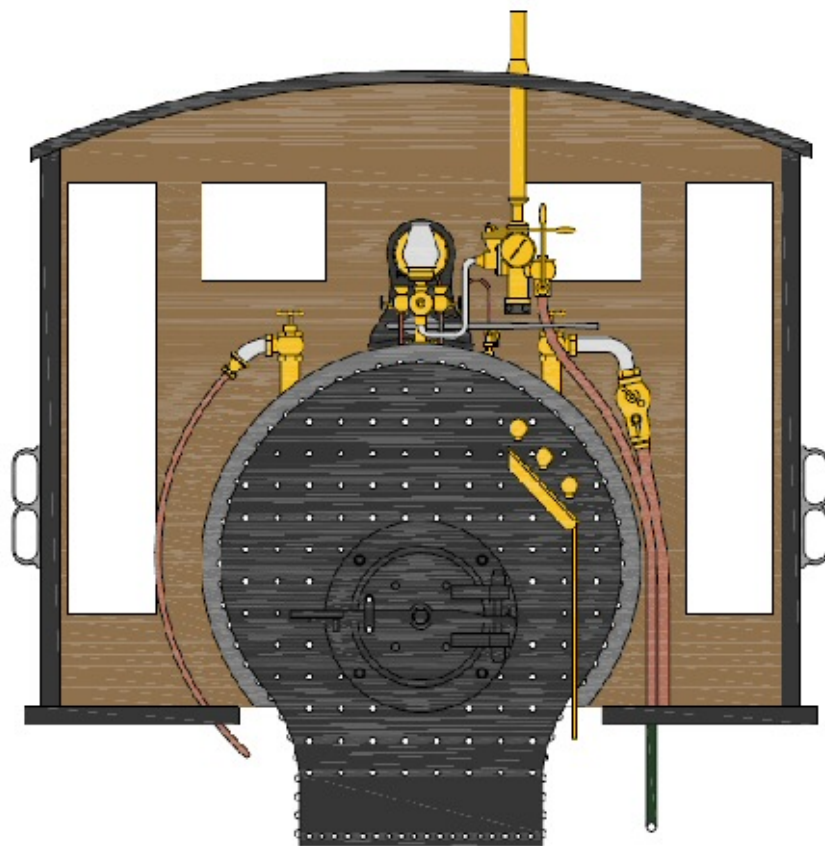

DSP&P #51 - CAB COLOUR SCHEME



BACKHEAD AND CAB INTERIOR COLOUR SCHEME
'AS BUILT' CONFIGURATION 1880

DSP&P #51 - 1880
DRAWN BY DAVID FLETCHER 2007

([click here for full size PDF file](#))

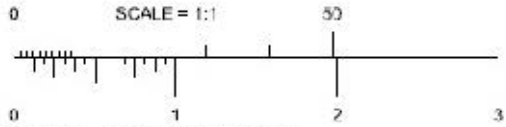

DSP 2-8-0 DETAILS
DSP&P #51 & #191

DRAWN BY DAVID FLETCHER 2007

[\(click here for full size PDF file \)](#)

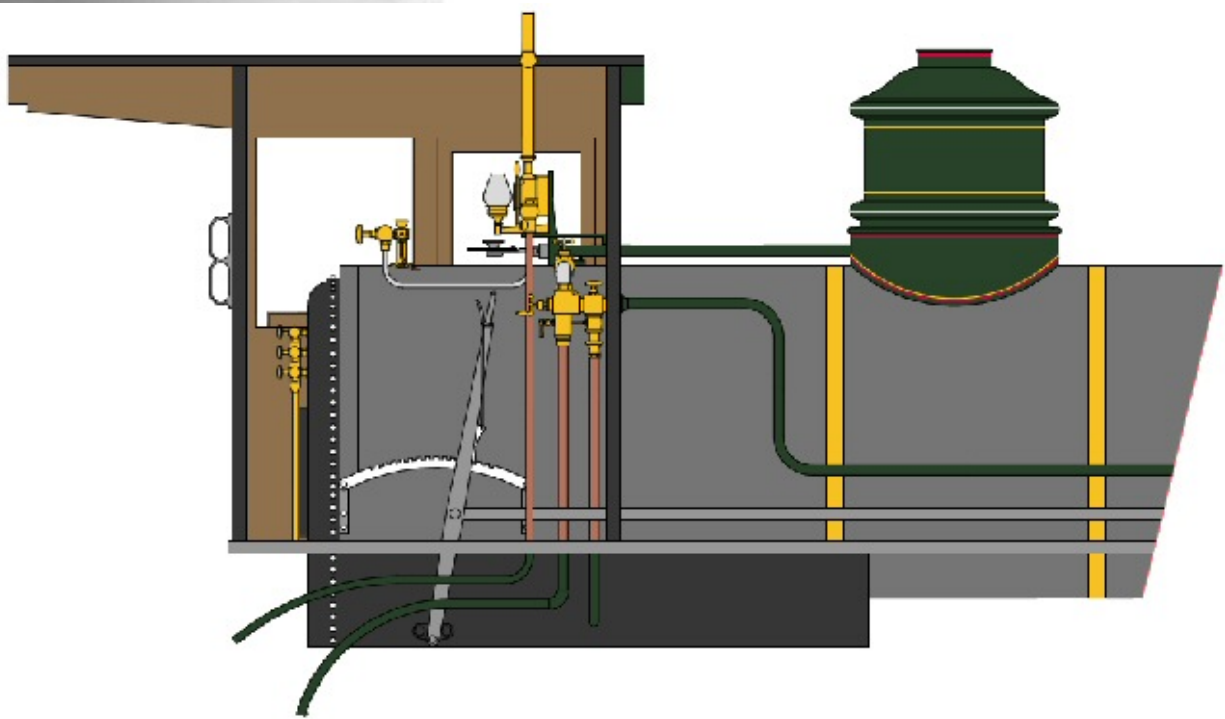

BACKHEAD AND CAB INTERIOR COLOUR SCHEME
'AS BUILT' CONFIGURATION 1880

DSP&P #51 - 1880
DRAWN BY DAVID FLETCHER 2007

[\(click here for full size PDF file \)](#)

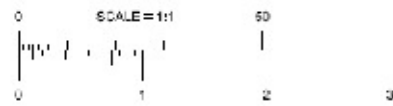
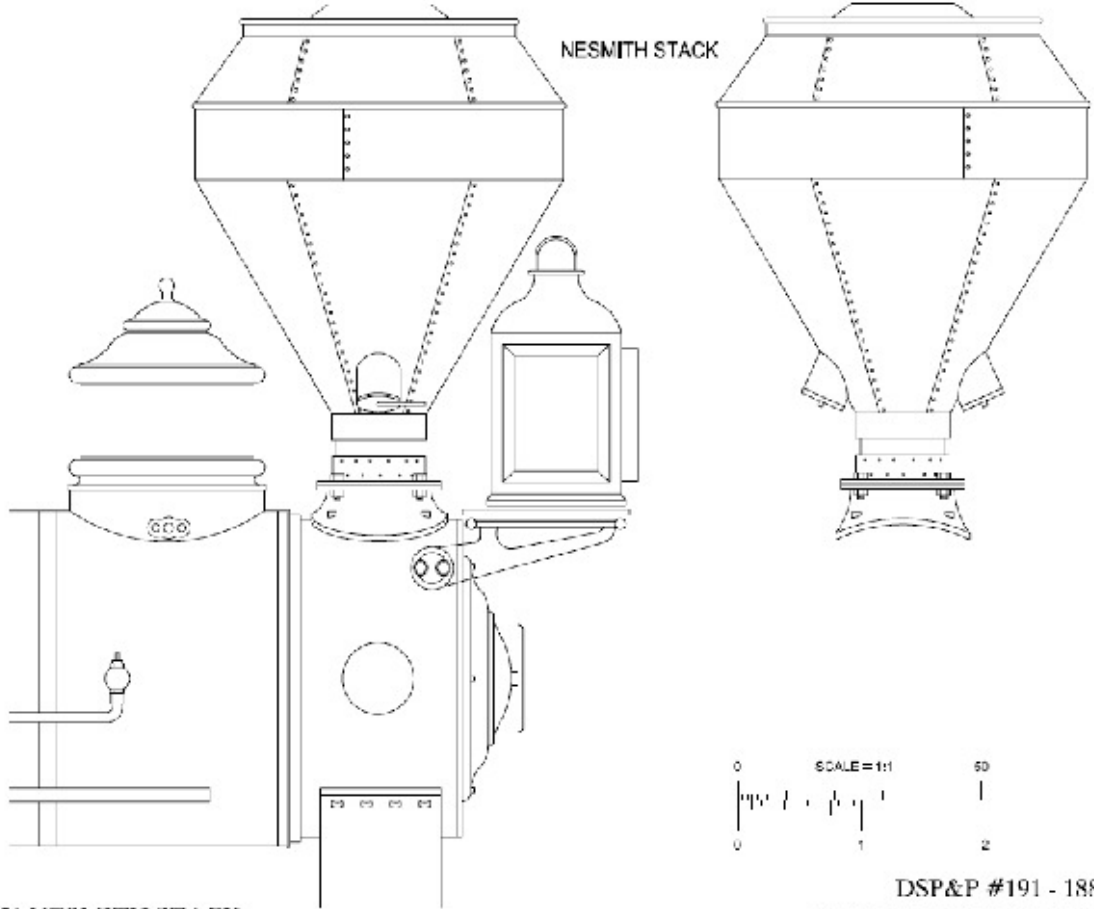

DSP&P #51 NESMITH STACK

DSP&P #191 - 1885
DRAWN BY DAVID FLETCHER 2007

([click here for full size PDF file](#))

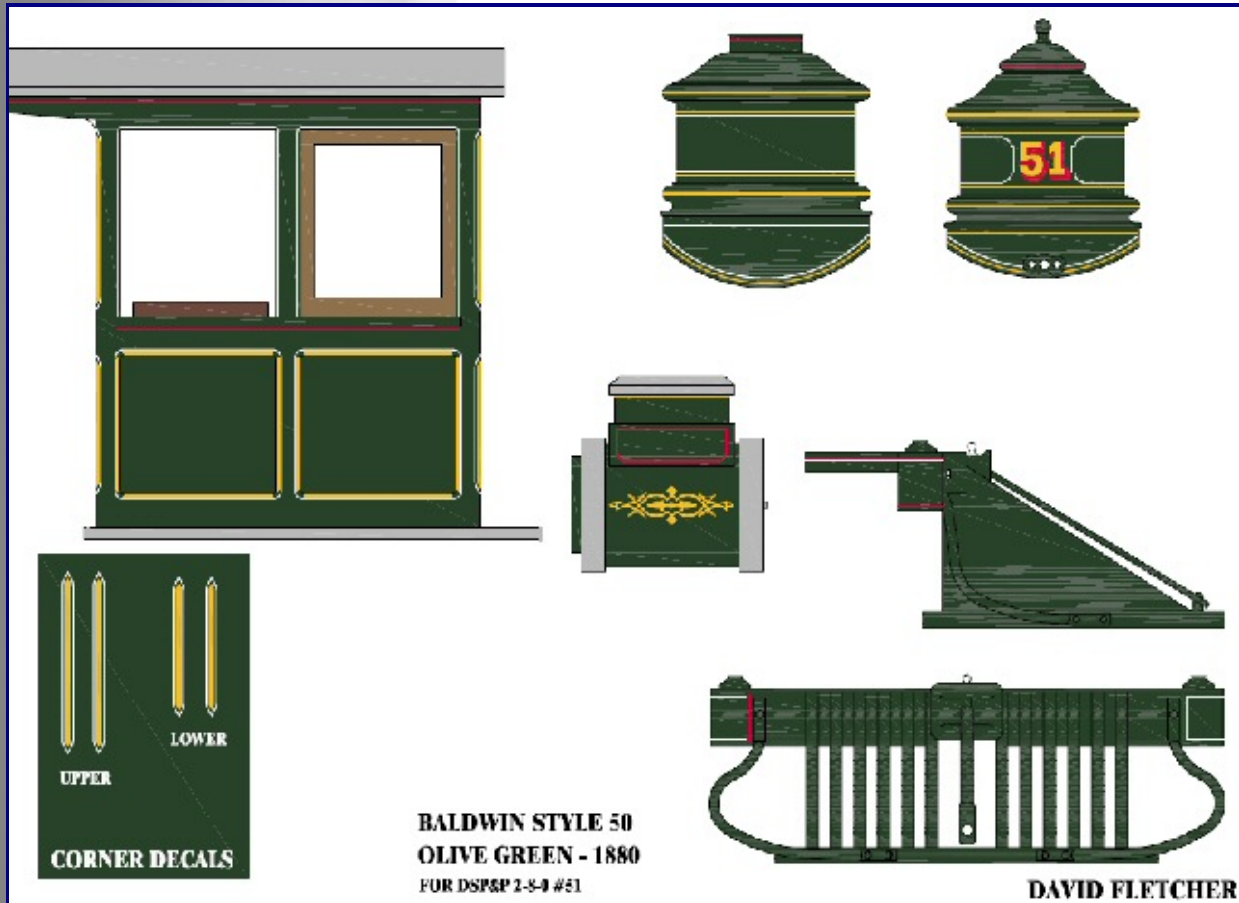

**BALDWIN STYLE 50
OLIVE GREEN - 1880
FOR DSP&P 2-8-0 #51**

DAVID FLETCHER

([click here for full size PDF file](#))



**BALDWIN STYLE 50
OLIVE GREEN - 1880
FOR DSP&P 2-8-0 #51**



STYLE 50 DRIVE WHEELS



PILOT WHEELS ONLY

DAVID FLETCHER

([click here for full size PDF file](#))

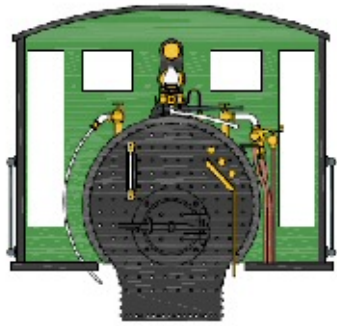

DSP&P #191 - CAB COLOUR SCHEME

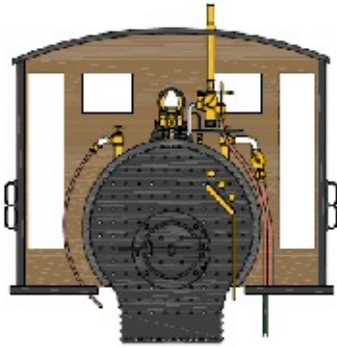
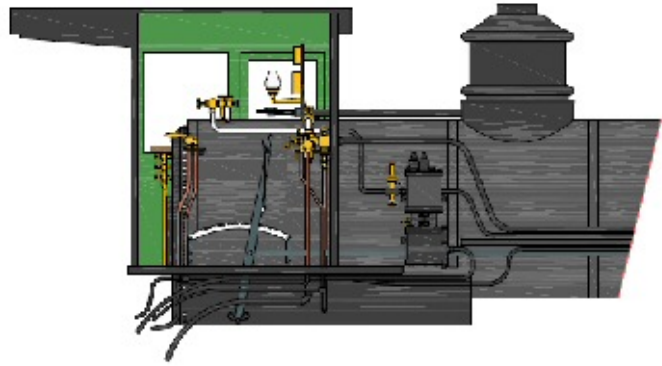

DSP&P #51 - CAB COLOUR SCHEME

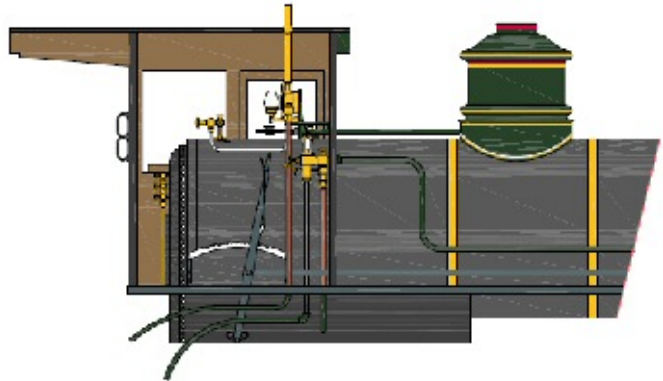

DSP&P # 51 & #191 - CAB COLOUR SCHEMES

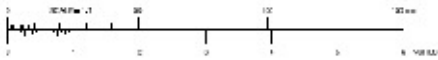

COPYRIGHT © DAVID FLETCHER 2007
ALL RIGHTS RESERVED

[\(click here for full size PDF file \)](#)



DSP&P #191 - 1885. - TENDER



GLASS LETTER BOARDS
OPAL WHITE LETTERS



DSP&P #51 - 1880. - TENDER

TENDER DETAIL CONCEPTS



COPYRIGHT © DAVID FLETCHER 2007
ALL RIGHTS RESERVED

([click here for full size PDF file](#))

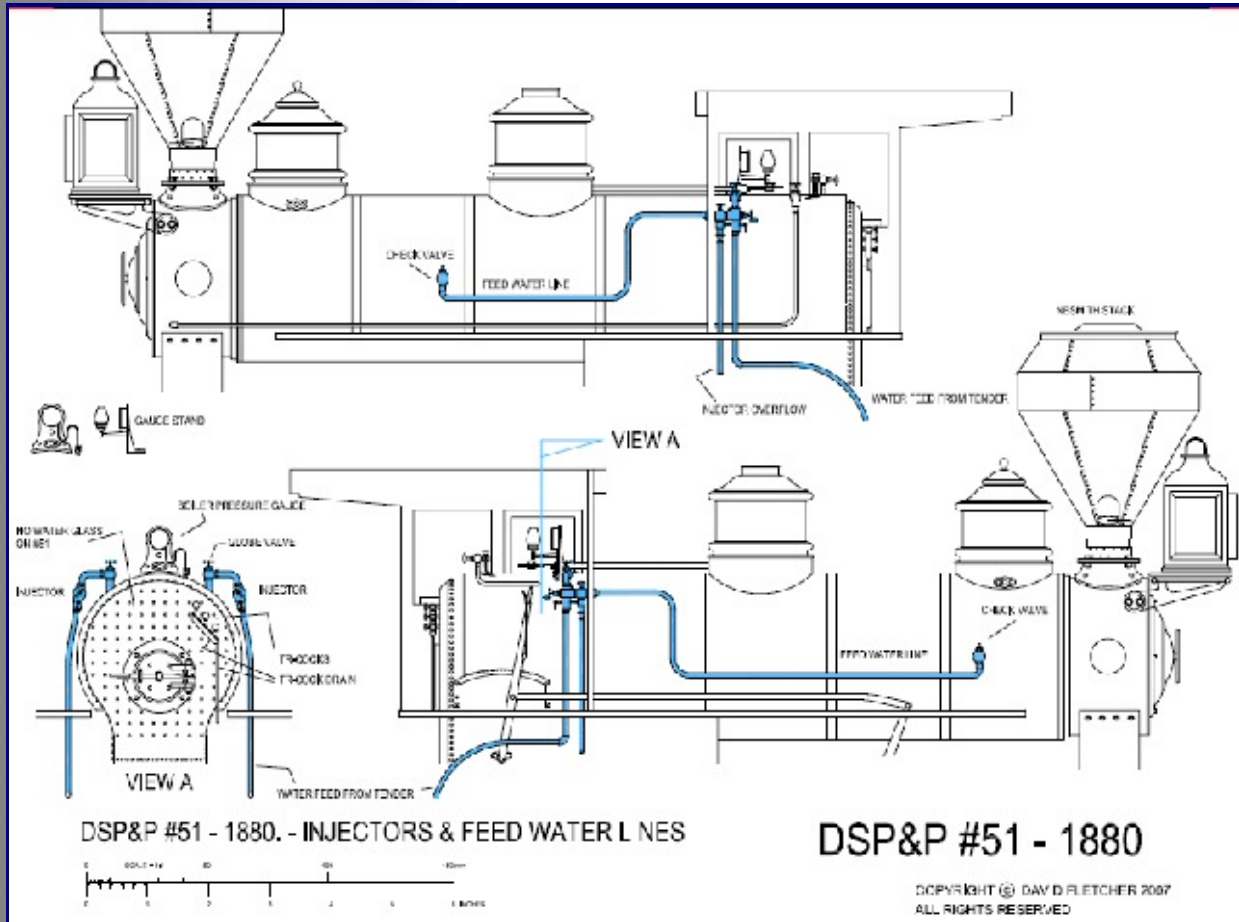

([click here for full size PDF file](#))

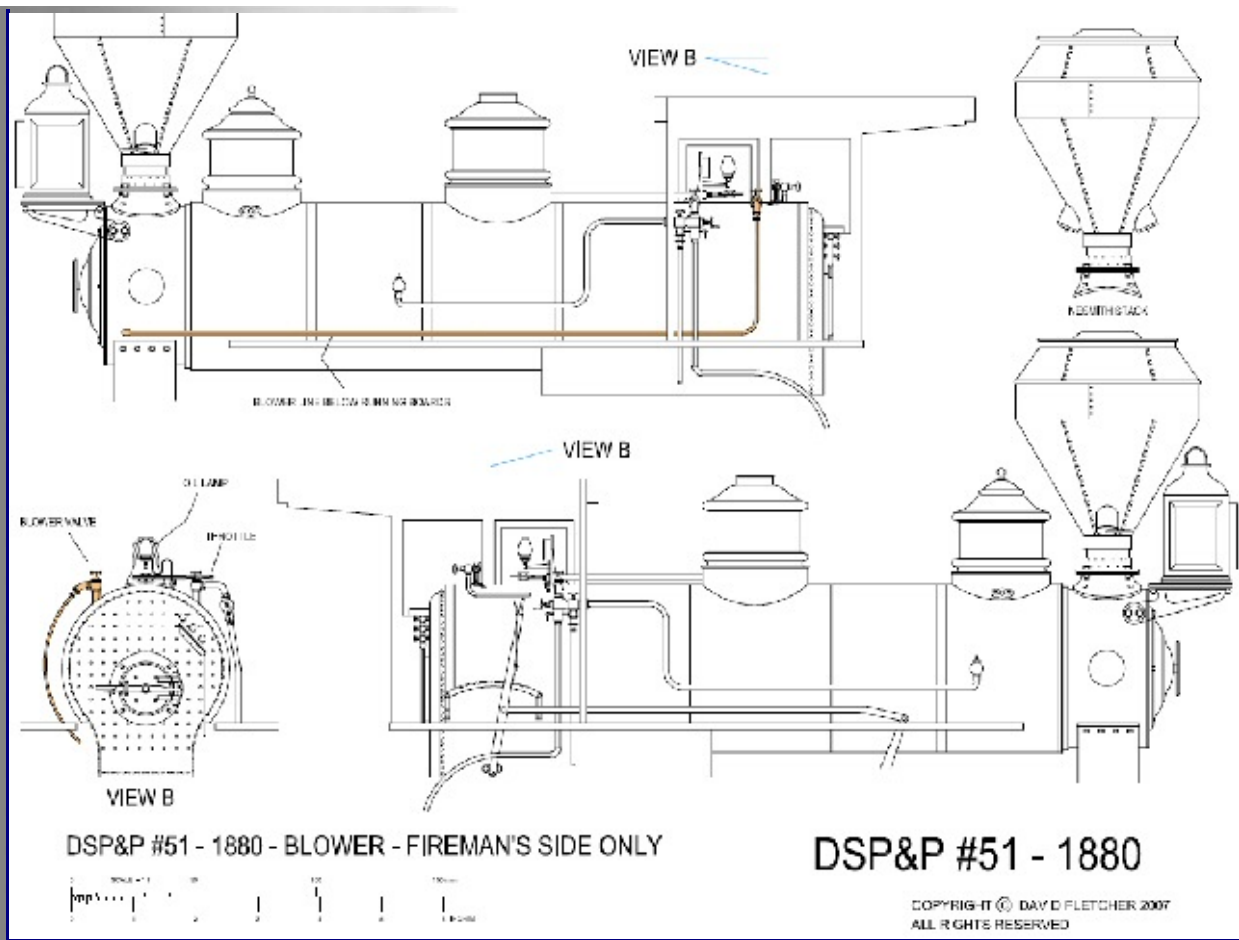

([click here for full size PDF file](#))

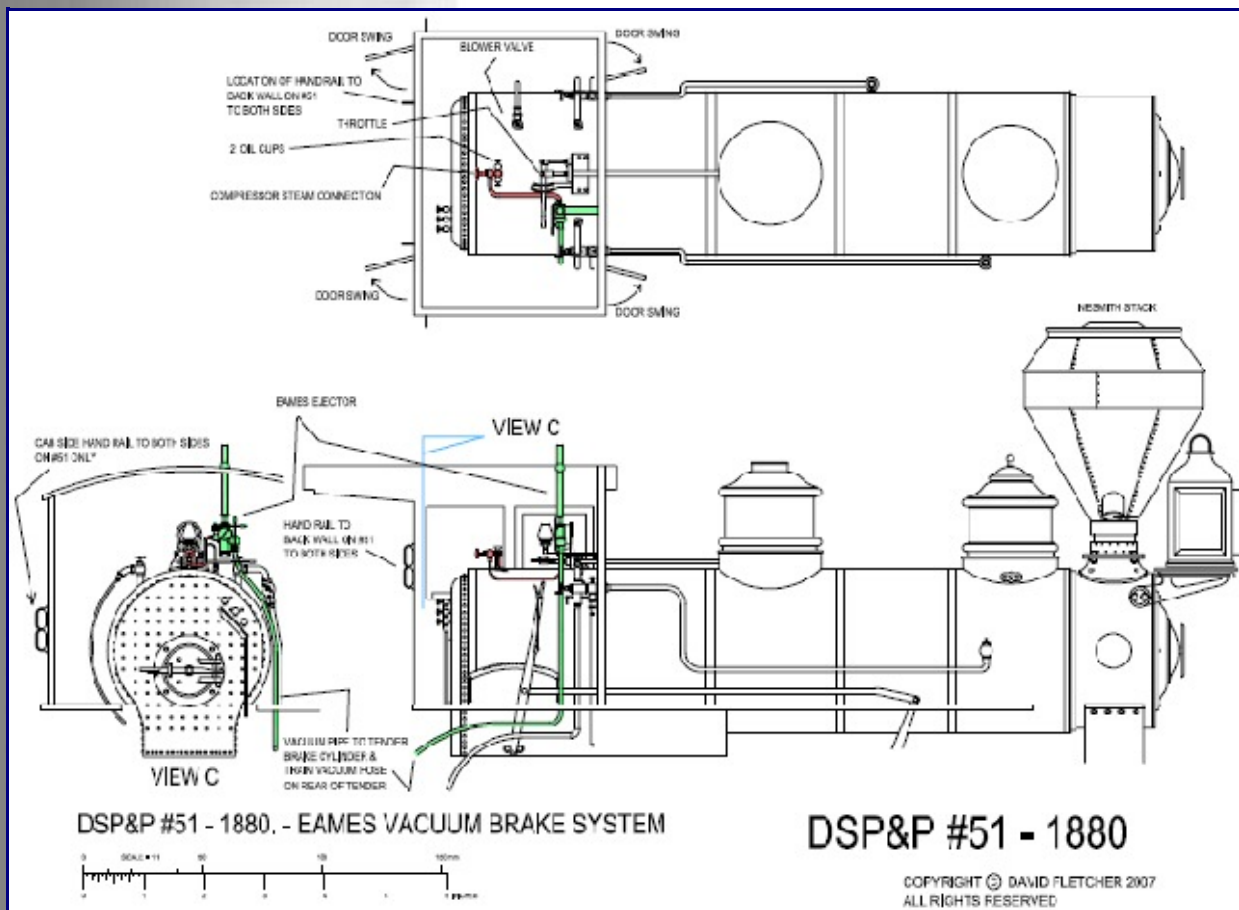

([click here for full size PDF file](#))

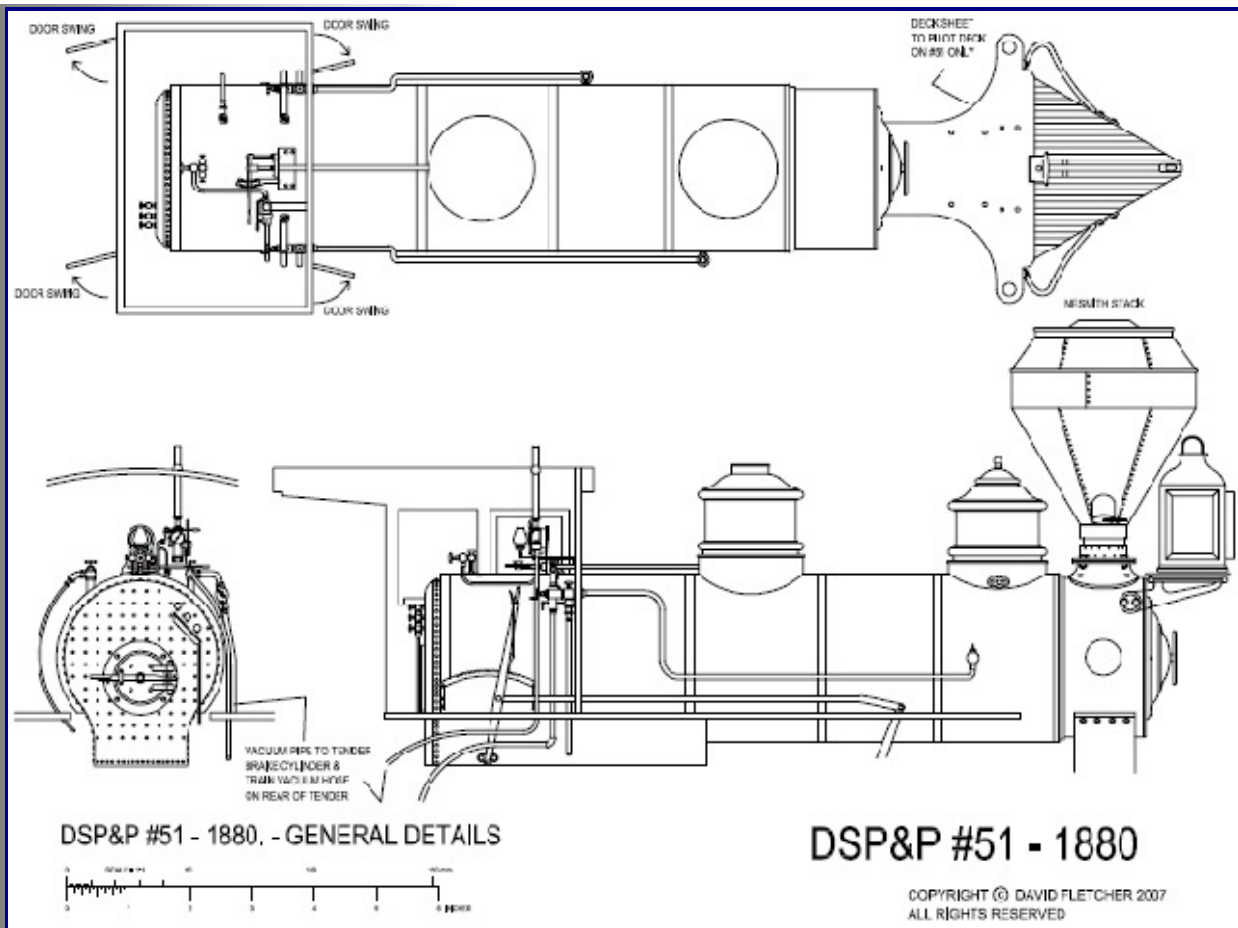

[\(click here for full size PDF file\)](#)

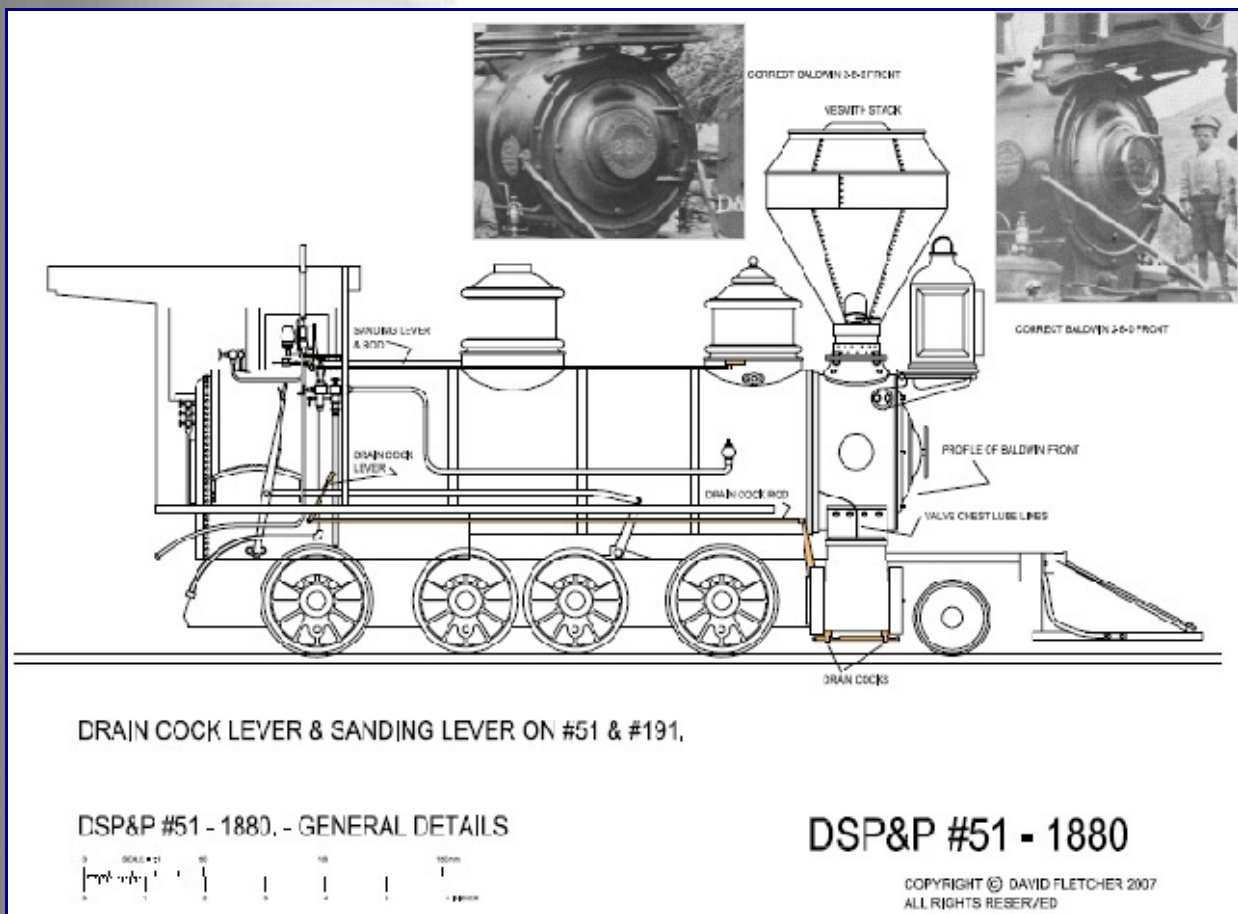

DRAIN COCK LEVER & SANDING LEVER ON #51 & #191.

[\(click here for full size PDF file\)](#)

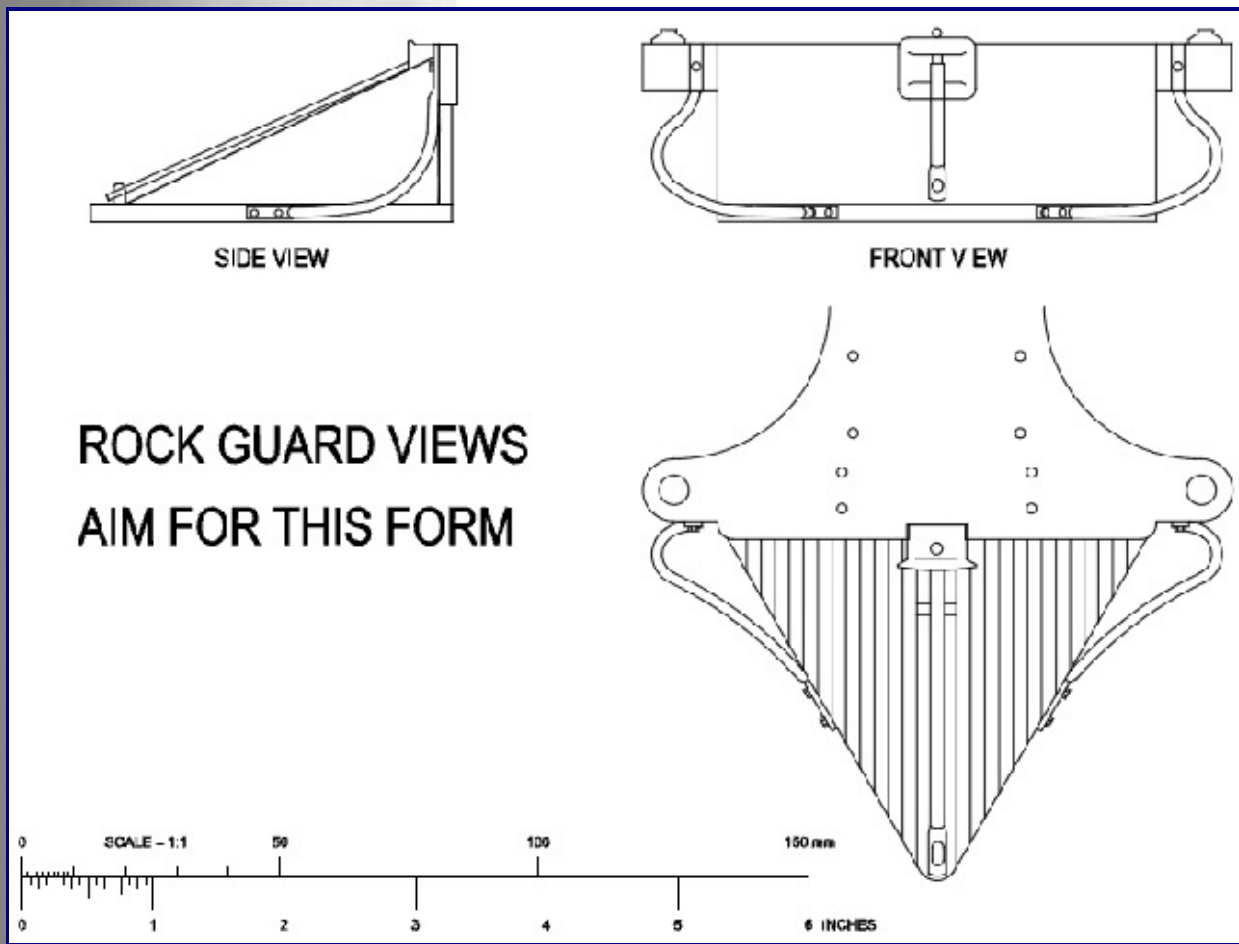
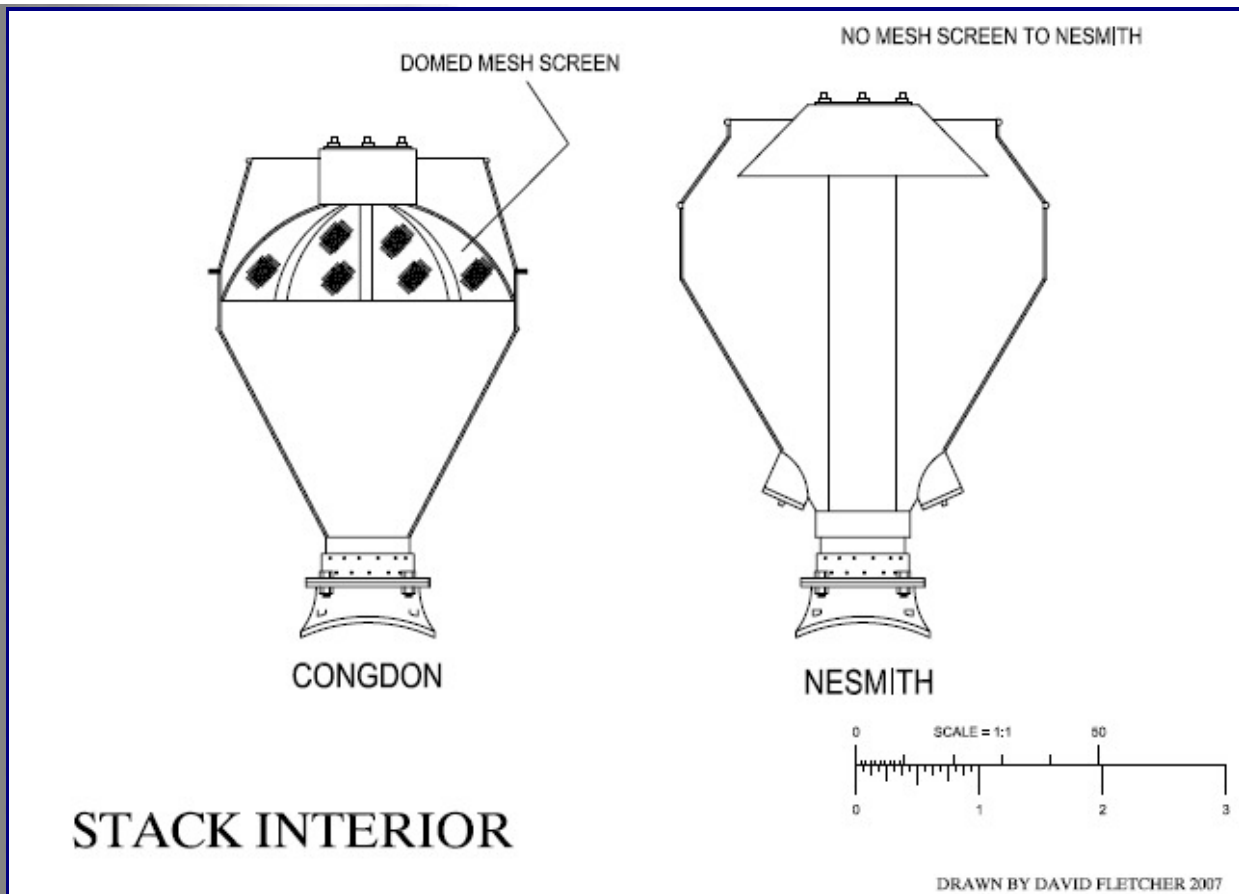

This is the Union Pacific's repaint to black of the DSP&P #191 in 1885.

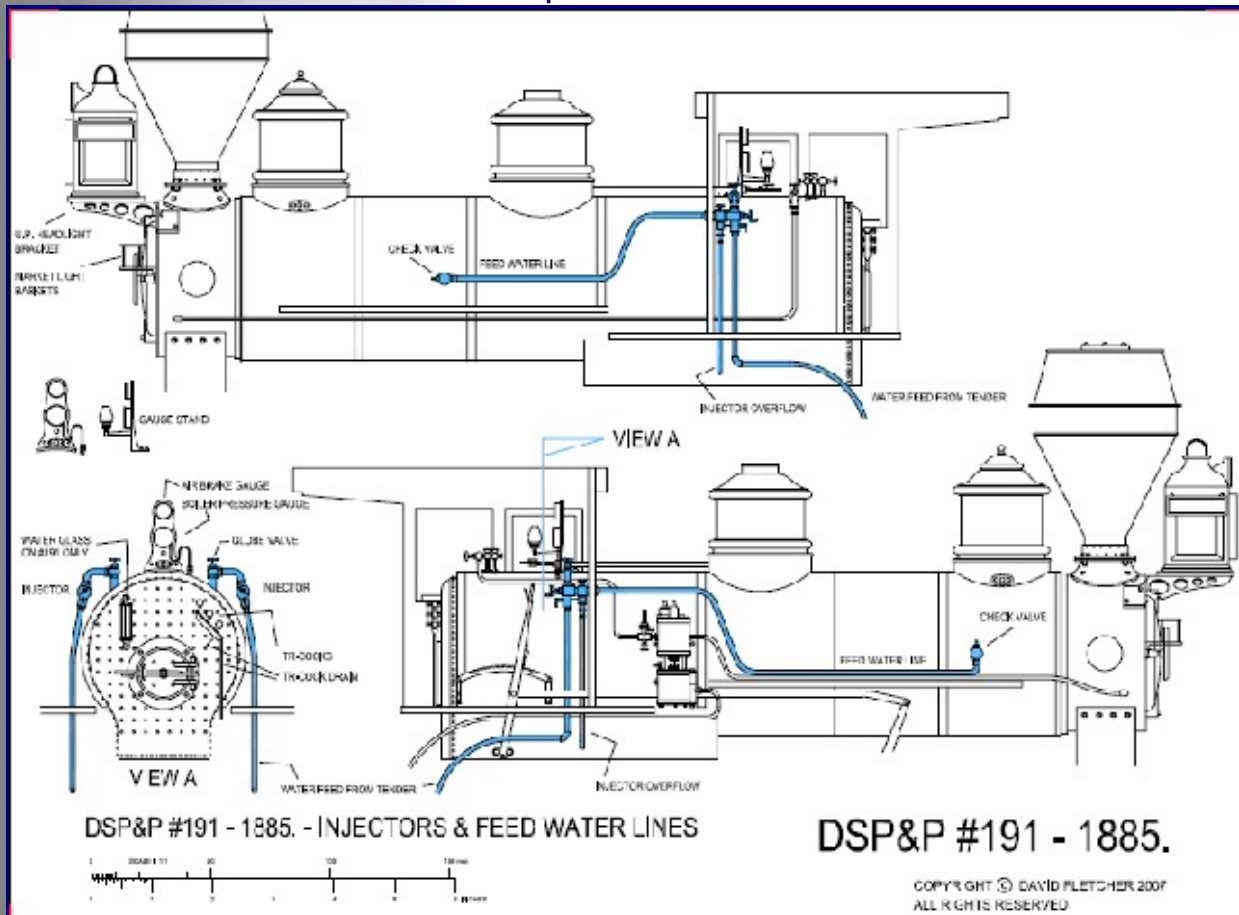

[\(click here for full size PDF file \)](#)

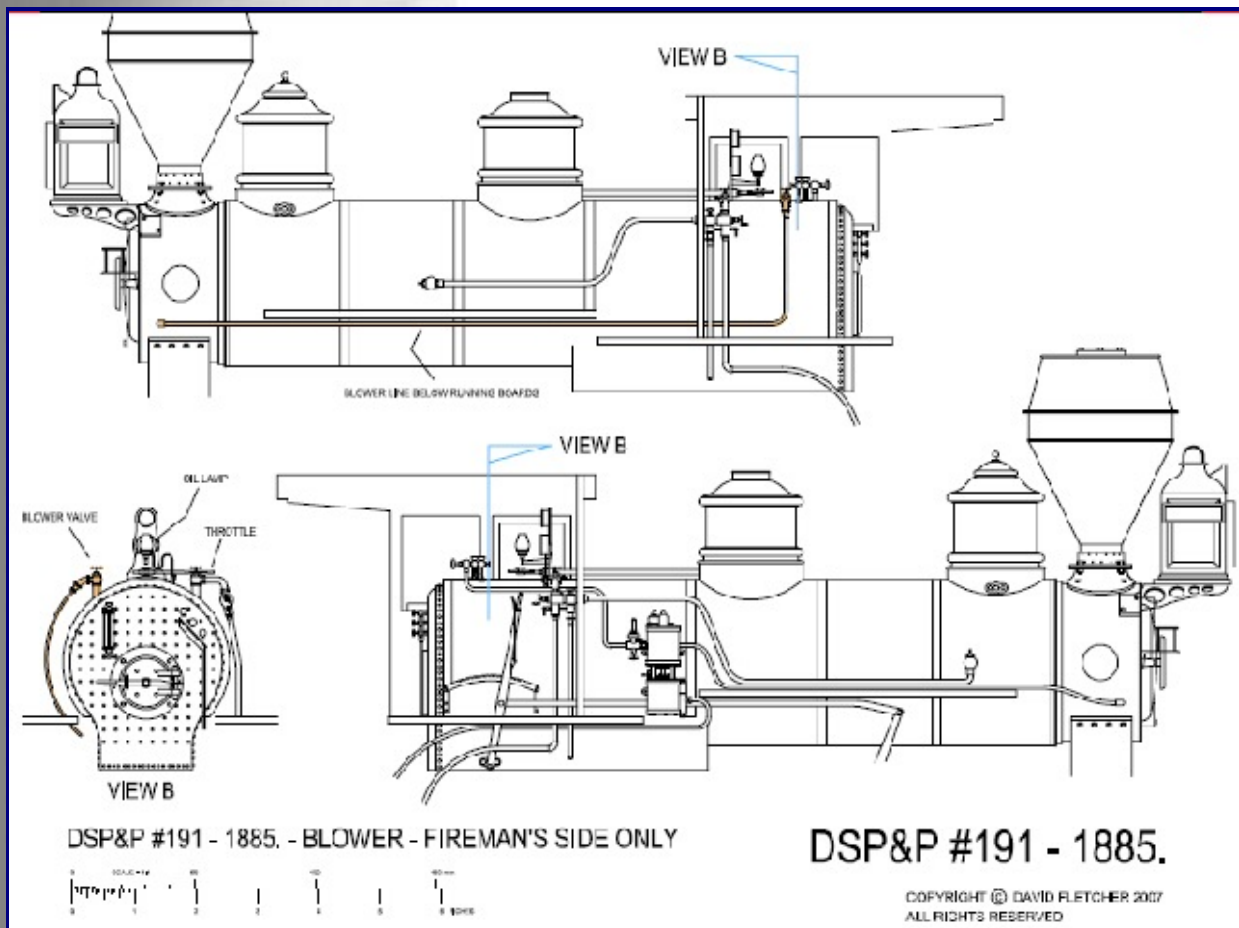

[\(click here for full size PDF file \)](#)

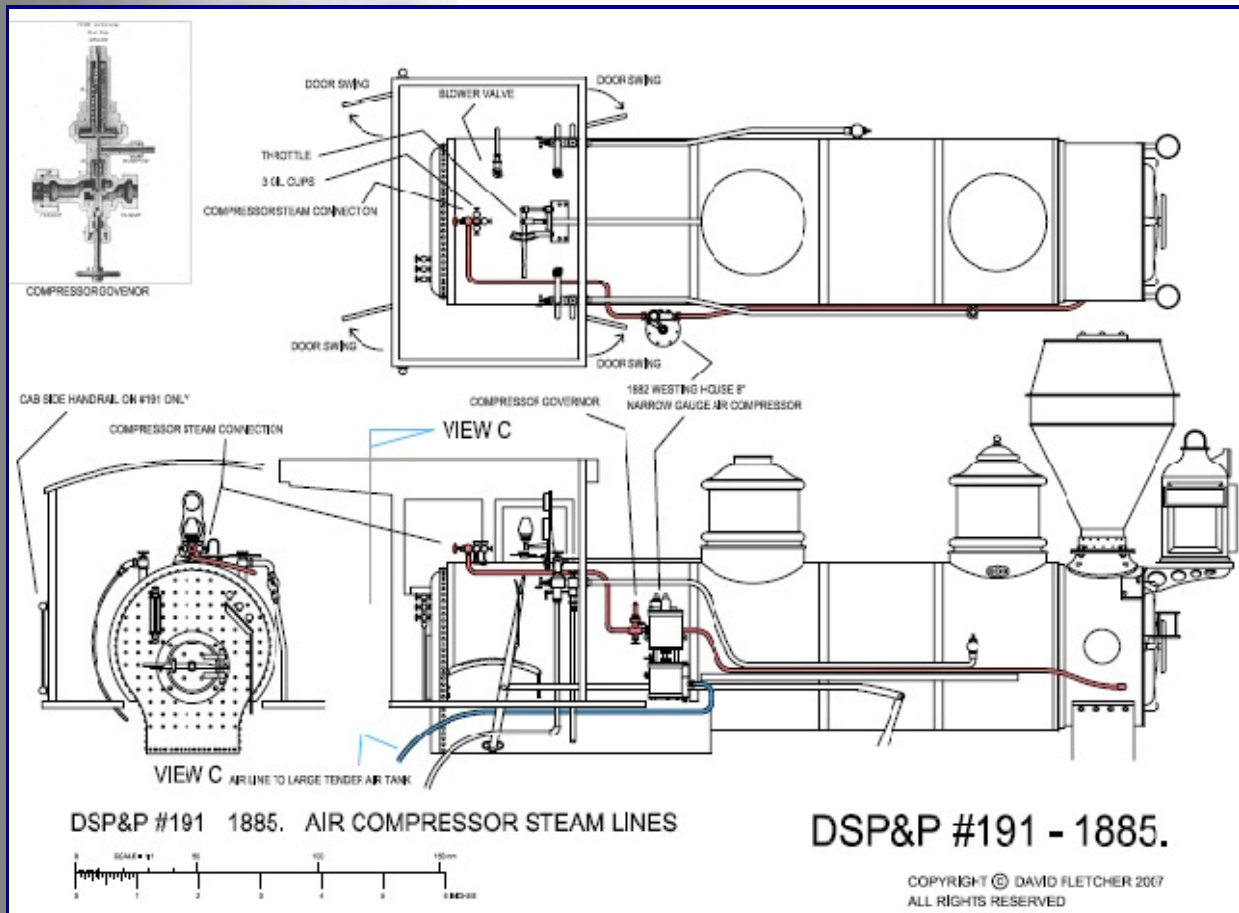

[\(click here for full size PDF file \)](#)

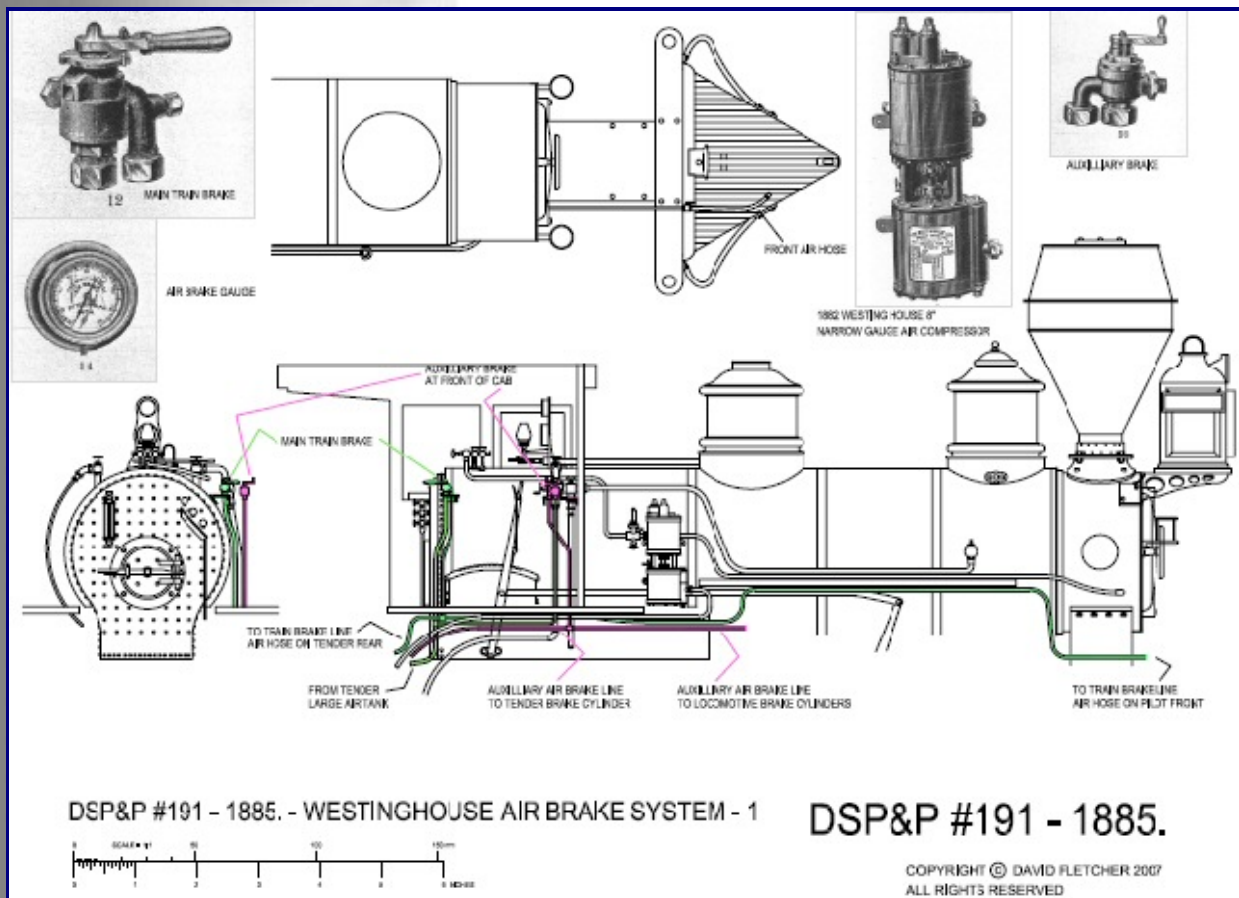

[\(click here for full size PDF file \)](#)

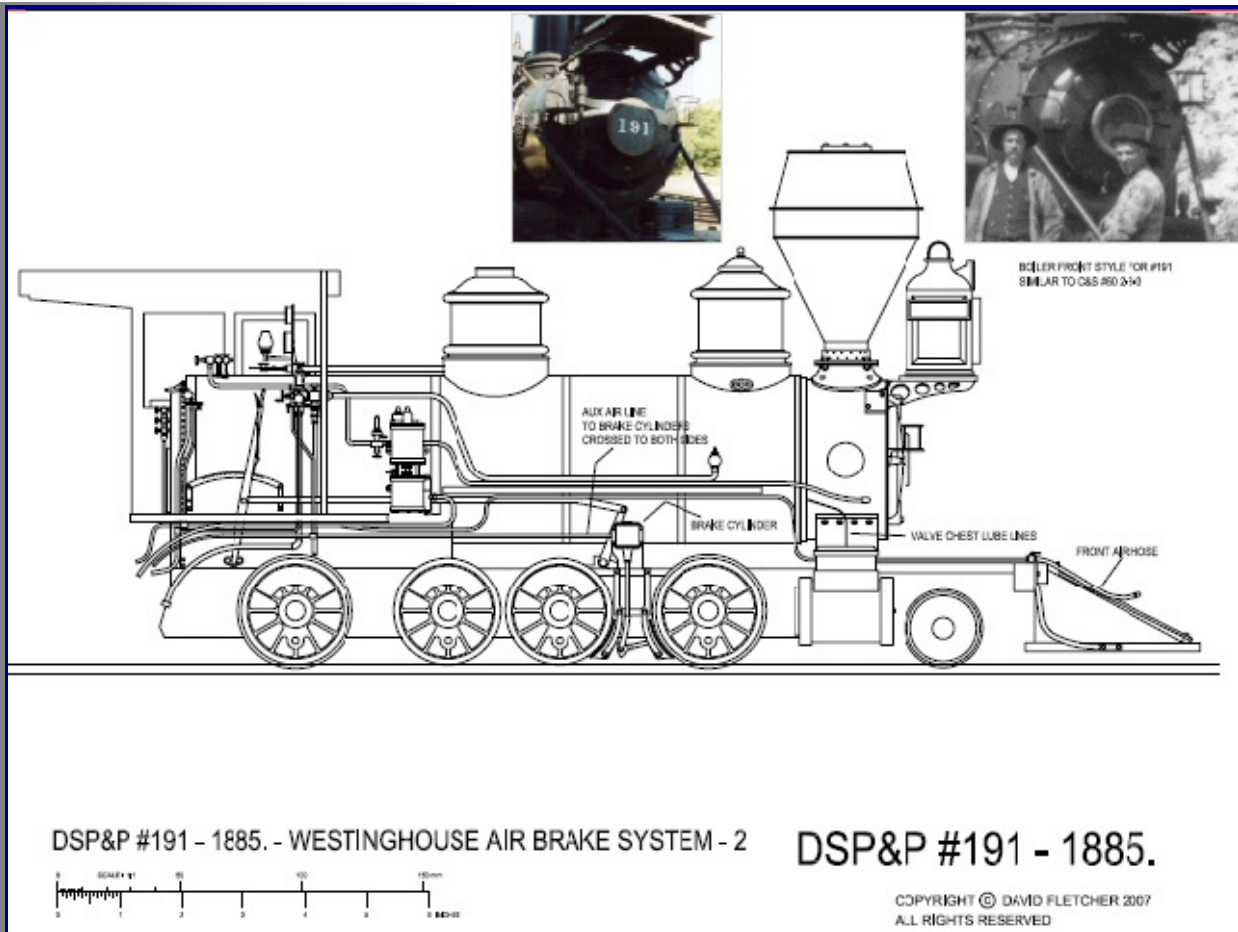

[\(click here for full size PDF file \)](#)

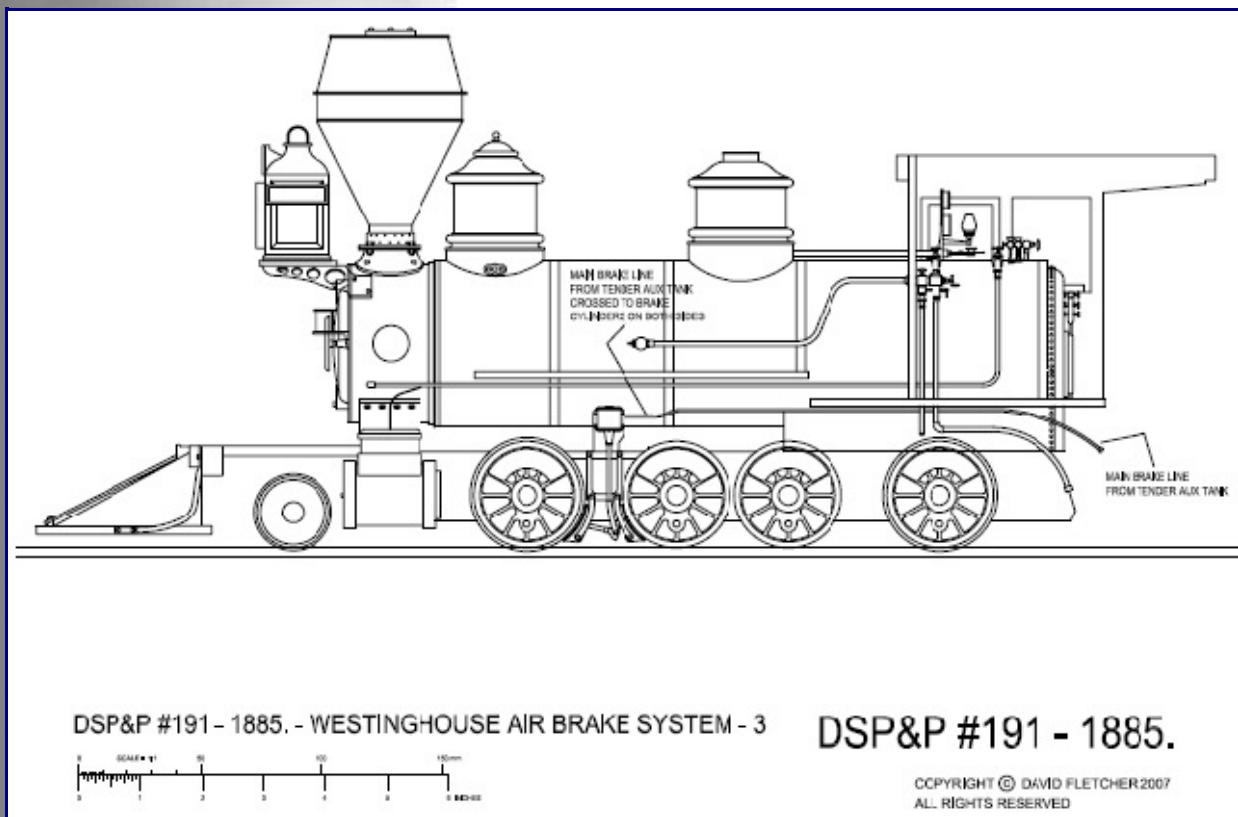

[\(click here for full size PDF file \)](#)